

# Rockcreter Mayco C30 Wetshotcrete Mechanical Piston Pump

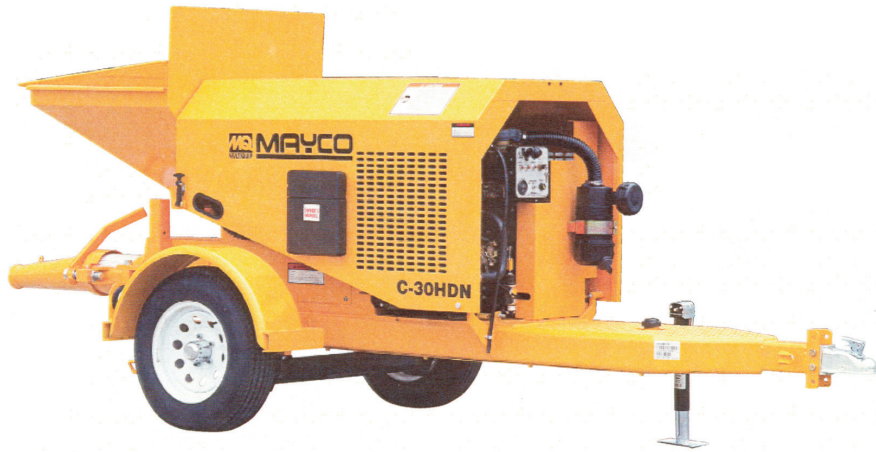

## FEATURES

- Designed in 1961 without changes in the USA
- No hydraulics, all mechanical
- Ball & seat pump operation, no s-tube
- Rockcreter Mayco pumps are designed to increase productivity and maximize profits
- Powerful engines - 51 HP Nissan gasoline or 32 HP Deutz engines - 11kw electric 3 phase
- Heavy-duty centrifugal clutch - for longer life
- Central lubrication system - enclosed lubrication box provides clean, positive piston lubrication
- Three-speed volume control - enables the operator to control the flow
- E-Z Open TM manifold - hinged for quick access to seats, cylinders, and piston cups. Easy open reducer
- Control box features engine hourmeter, temperature warning light, battery warning light

## APPLICATIONS

- Masonry grouting
- Shotcrete (wet gunning)
- Swimming pools
- Slope stabilization
- Channel lining - flood control
- Vault and crypt construction
- Lining - irrigation ditches & reservoirs
- Foundation work
- Slabs and basements
- Swimming pool decks and patios
- Cellular foam concrete
- Concrete pilings
- Column work
- Pressure grouting and mud jacking

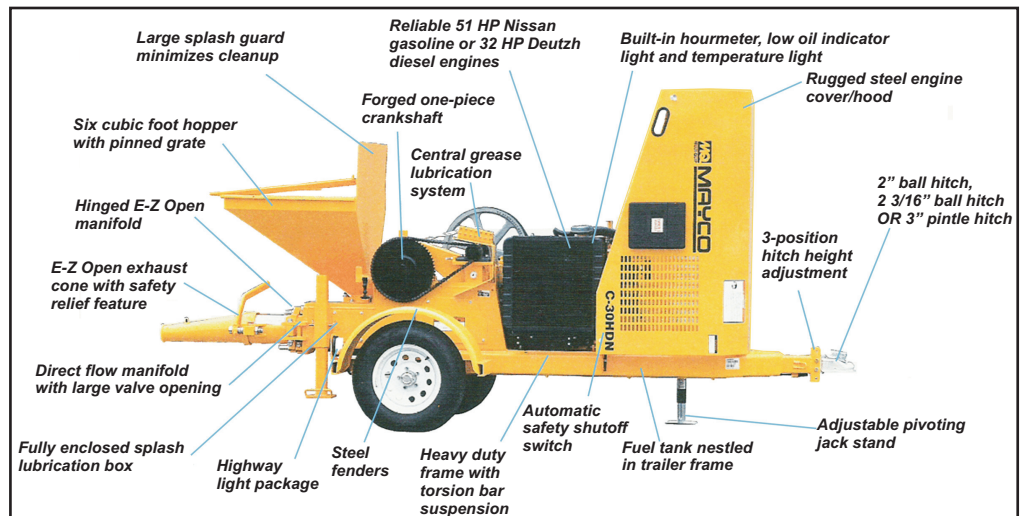

## PERFORMANCE

- Pumping Rate  
25 cu. yds. (19 m<sup>3</sup>) per hour\*
- Maximum Aggregate Size  
½" minus (12 mm)
- Vertical Pumping Height  
Excess of 150 ft. (46 m)\*
- Horizontal Pumping Distance  
500 ft. (152 m)\*
- Concrete Piston Face Pressure  
500+ psi

## ENGINEERING

- Engines  
11kw 380V/525V Electric motor  
C30HDNI: 51 HP Nissan A15 Gasoline Fuel Injection  
C30HDZ: 32 HP Deutz F2L2011 Diesel Powered
- Pump  
Reciprocating piston
- Hopper Capacity  
6 cu. ft. (.17 m<sup>3</sup>)
- Material Hose  
2", 2½" (5 cm, 6.4 cm)

## DIMENSIONS

- L x W x H  
144 x 59 x 64.5 in.  
(366 x 149 x 164 cm)
- Weight  
2,831 lbs. (1284 kg)

## OPTIONAL EQUIPMENT

- Air vibrator mounted to hopper screen
- Diesel engine
- Skid mount
- Wetgun nozzle
- Reducers
- Steel pipe
- Couplings
- Concrete/grout hose

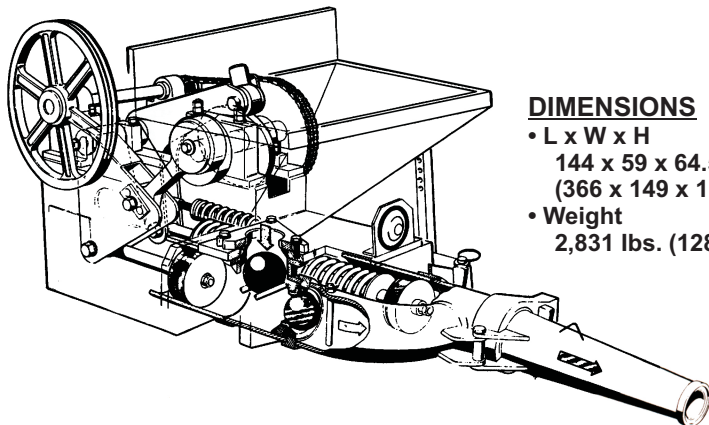

\* These figures will vary due to mix design, line size, and job site conditions

P.O. Box 18924 Sunward Park 1470 • Log Road, Roodekop, Alberton, South Africa  
Company Reg. No: 1947/24677/07

Tel: +27 11 865 3019/59/71 • Fax: +27 11 865 1346  
email: [information@rockcrete.co.za](mailto:information@rockcrete.co.za)  
website: [www.rockcrete.co.za](http://www.rockcrete.co.za)

As part of our policy of constant product development and improvement, information and specifications contained in this document are liable to change

